

# 105F-5

# MINIATURE HIGH POWER RELAY



### Features

- 30A switching capability
- PCB coil terminals, ideal for heavy duty load
- Heavy load up to 7,200VA
- Open, sealed & unsealed types available
- Class B, Class F insulation available
- 4KV dielectric strength  
(between coil and contacts)
- Environmental protection product available  
(RoHs & WEEE compliant)

### CONTACT DATA

Contact Arrangement	1A	1B	1C (NO)	1C (NC)
Initial Contact Resistance	50mΩ (at 1A 24VDC)			
Contact Material	AgSnO <sub>2</sub> , AgCdO			
Max. Switching Capacity	7200VA/560W	3600VA/280W	4800VA/560W	2400VA/280W
Max. Switching Voltage	277VAC/28VDC			
Max. Switching Current	30A	15A	20A	10A
JQX-105F-5 Rating	30A 240VAC 20A 28VDC	15A 240VAC 10A 28VDC	20A 240VAC 20A 28VDC	10A 240VAC 10A 28VDC
JQX-105F-5L Rating	25A 240VAC 20A 28VDC	15A 240VAC 10A 28VDC	20A 240VAC 20A 28VDC	10A 240VAC 10A 28VDC
Mechanical life	1 x 10 <sup>7</sup> OPS			
Electrical life	1 x 10 <sup>5</sup> OPS			

### COIL

Coil power	DC:0.9W AC:2VA
Coil Voltage	5 to 110VDC 12 to 277VAC
Coil Resistance	See table below

### SAFETY APPROVAL RATINGS

UL	1 Form A	30A 277VAC
		30A 28VDC
	1 Form B (NC)	2HP 250VAC
		1HP 125VAC
		277VAC(FLA=20)(LRA=60)
		15A 277VAC
1 Form C	NO	10A 28VDC
		2HP,250VAC
		1HP,125VAC
	NC	277VAC(FLA=20)(LRA=60)
		20A 277VAC
		10A 277VAC
TüV		10A 28VDC
		1/2HP 250VAC
		1/4HP 125VAC
		277VAC(FLA=10)(LRA=33)

### CHARACTERISTICS

Initial Insulation Resistance	1000MΩ, 500VDC	
Dielectric Strength	Between coil and Contacts	2500/4000VAC, 1min.
	Between open contacts	1500VAC 1min.
Operate time (at nomi. Volt.)	Max. 15ms	
Release time (at nomi. Volt.)	Max. 10ms	
Ambient temperature	Class B	DC:-55°C to +85°C AC:-55°C to +60°C
	Class F	DC:-55°C to +105°C AC:-55°C to +85°C
Shock Resistance	Functional	98 m/s <sup>2</sup>
	Destructive	980 m/s <sup>2</sup>
Vibration Resistance	DA:1.5mm, 10 to 55Hz	
Humidity	98%, +40°C	
Termination	PCB & QC	
Unit weight	Approx.36g	
Construction	Sealed IP67, Dust cover,	

## COIL DATA

Nominal Voltage VDC	Pick-up Voltage VDC	Drop-out Voltage VDC	Max. allowable Voltage VDC(at 25°C)	Coil Resistance Ω
5	3.75	0.5	6.5	27 ± 10%
6	4.50	0.6	7.8	40 ± 10%
9	6.75	0.9	11.7	97 ± 10%
12	9.00	1.2	15.6	155 ± 10%
15	11.25	1.5	19.5	256 ± 10%
18	13.50	1.8	23.4	380 ± 10%
24	18.00	2.4	31.2	660 ± 10%
48	36.00	4.8	62.4	2560 ± 10%
70	52.50	7.0	91	5500 ± 10%
110	82.50	11	143	13450 ± 10%

Nominal Voltage VAC	Pick-up Voltage VAC	Drop-out Voltage VAC	Max. allowable Voltage VDC(at 25°C)	Coil Resistance Ω
12	9.6	2.4	15.6	25 ± 10%
24	19.2	4.8	31.2	100 ± 10%
120	96.0	24.0	156	2500 ± 10%
208	166.4	41	270.4	11000 ± 10%
220/240	192	48	286/312	13490 ± 10%
277	220	54	360.1	15000 ± 10%

**Note:**When require pick-up voltage < 80% of nominal voltage, special order allowed.

## ORDERING INFORMATION

Type	JQX-105F-5 / 018	D	T	1H	S	T	F	XXX
JQX-105-5: Open JQX-105F-5L: 25A JQX-105F-5: 30A								
<b>Coil voltage</b>	DC: 5 to 110VDC AC: 12 to 277VAC							
<b>Coil Input</b>	D: DC A: AC							
<b>Dielectric Strength</b>	T: Dielectric strength between coil and contact: 4000VAC Nil: 2500VAC							
<b>Contact arrangement</b>	1H:1A(SPST-NO) 1D:1B(SPST-NC) 1Z:1C(SPDT)							
<b>Structure</b>	S: Sealed IP67 Nil: Dust cover							
<b>Contact Material</b>	T: AgSnO <sub>2</sub> Nil: AgCdO							
<b>Insulation Standard</b>	F: Class F Nil: Class B							
<b>Special request code</b>	( For example: 551: Lead-free 555: RoHs & WEEE compliant )							

## OUTLINE DIMENSIONS, WIRING DIAGRAM AND PC BOARD LAYOUT

### Outline Dimensions

JQX-105F-5L (Sealed & unsealed)

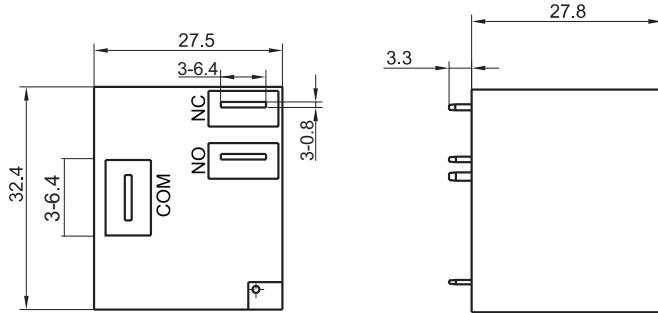

### Wiring Diagram & PCB layout

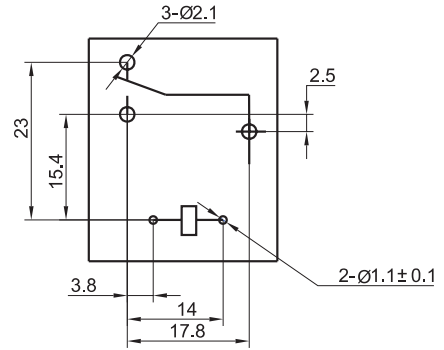

## CHARACTERISTICS CURVE

### COIL TEMPERATURE RISE

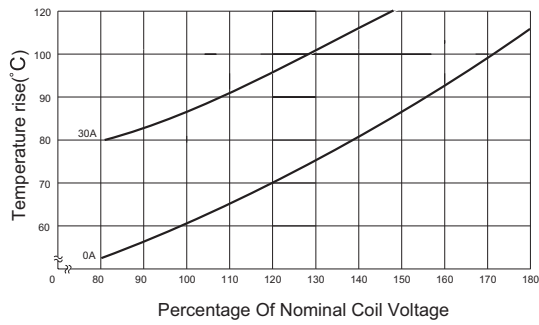

### MAXIMUM SWITCHING POWER

